

DATA SHEET

25 FRAME PLUNGER PUMPS



Brass Model: **2510**

Stainless Steel Model: **2511**

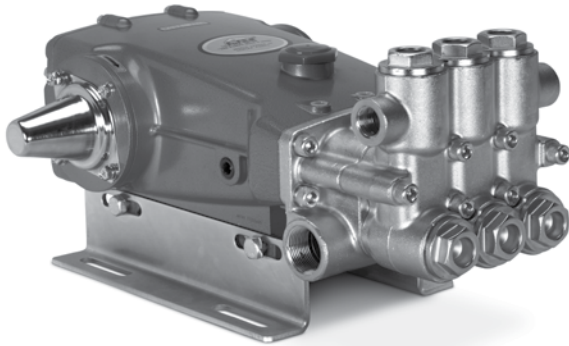

Model 2510 Shown
(Rails and shaft protector sold separately)

FEATURES

- Triplex design delivers high efficiency and low pulsation.
- Durable dual V-Packings are lubricated and cooled by pumped liquid.
- Pre-set Lo-Pressure seals provide secondary protection against external leaks and require no packing adjustments.
- Standard NBR seals with alternative options for temperature and chemical compatibility
 - FPM – .0110
 - EPDM – .0220
 - High Temp, 200° F (Intermittent Run Dry) – .3400 or .3410

COMMON

SPECIFICATIONS	U.S.	Metric
Pump RPM*	1450 rpm	1450 rpm
Inlet Pressure Range	Flooded to 70 psi	Flooded to 4.9 bar
Bore	0.984"	25 mm
Stroke	1.516"	38.5 mm
Max. Liquid Temperature	140°F	60°C
Above 130°F call Cat Pumps for inlet conditions and elastomer recommendations.		
Crankcase Capacity	84 oz.	2.5 l
Inlet Ports (2)	1-1/4" NPT(F)	1-1/4" NPT(F)
Discharge Ports (2)	3/4" NPT(F)	3/4" NPT(F)
Pulley Mounting	Either side	Either side
Shaft Diameter	1.181"	30 mm
Weight (2510)	79 lbs.	36 kg
(2511)	75 lbs.	34 kg
Dimensions	20.16 x 15.04 x 8.66"	512 x 382 x 220 mm

*Pump minimum is 100 RPM.

SPECIFICATIONS	U.S. Measure	Metric Measure
2510		
Flow	20 gpm	76 lpm
Pressure Range	100 to 2000 psi	6.9 to 138 bar
2511		
Flow	20 gpm	76 lpm
Pressure Range	100 to 1500 psi	6.9 to 103 bar

ELECTRIC HORSEPOWER REQUIREMENTS

MODEL	FLOW		PRESSURE					RPM
			psi 1000	psi 1200	psi 1500	psi 1800	psi 2000	
	U.S. gpm	lpm	bar 69	bar 83	bar 103	bar 124	bar 138	
2510	20	76	13.7	16.5	20.6	24.7	27.5	1450
	18	68	12.3	14.8	18.5	22.2	24.7	1305
	15	57	10.3	12.4	15.4	18.5	20.6	1088
2511	20	76	13.7	16.5	20.6	N/A	N/A	1450
	18	68	12.3	14.8	18.5	N/A	N/A	1305
	15	57	10.3	12.4	15.4	N/A	N/A	1088

DETERMINING THE PUMP R.P.M. $\frac{\text{Rated gpm}}{\text{Rated rpm}} = \frac{\text{"Desired" gpm}}{\text{"Desired" rpm}}$

DETERMINING THE REQUIRED H.P. $\frac{\text{Hp (Electric Brake)}}{1460} = \frac{\text{gpm x psi}}{1460}$

DETERMINING MOTOR PULLEY SIZE $\frac{\text{Motor Pulley O.D.}}{\text{Pump rpm}} = \frac{\text{Pump Pulley O.D.}}{\text{Motor rpm}}$

See complete Drive Packages [Includes: pulleys, belts, hubs, key] Tech Bulletin 003. Refer to pump **Service Manual** for repair procedure and additional technical information.

PARTS LIST

ITEM	PART NUMBER	MATL	PART NUMBER	MATL	DESCRIPTION	QTY
	2510		2511			
2	990036	STL	990036	STL	Key (M8x7x40)	1
5	126544	STCP R	125753	S	Screw, HHC Sems (M8x25)	8
8	27773	AL	27773	AL	Cover, Bearing (See Tech Bulletin 118)	2
10	27772	NBR	27772	NBR	O-Ring, Bearing Cover - 70D	2
11	27771	NBR	27771	NBR	Seal, Oil, Crankshaft - 70D	2
15	26512	STL R	26512	STL R	Bearing, Ball	2
20	48613	TNM	48613	TNM	Rod, Connecting Assembly (Includes: Lockwasher, Washer, Screw)	3
21	126562	STCP R	126562	STCP R	Washer, Locking	3
25	49795	FCM	49795	FCM	Crankshaft, Dual-End	1
31	828710	PE	828710	PE	Protector, Oil Cap w/Foam Gasket	1
32	43211	ABS	43211	ABS	Cap, Oil Filler	1
33	14177	NBR	14177	NBR	O-Ring, Oil Filler Cap - 70D	1
38	129343	RBR	129343	RBR	Gasket, Flat	1
39	27769	ABS	27769	ABS	Dip Stick	1
40	126544	STCP R	125753	S	Screw, HHC Sems (M8x25)	8
48	25625	STCP	25625	STCP	Plug, Drain (1/4"x19BSP)	1
49	23170	NBR	23170	NBR	O-Ring, Drain Plug - 70D	1
50	27768	AL	27768	AL	Cover, Rear (See Tech Bulletin 118)	1
51	27767	NBR	27767	NBR	O-Ring, Rear Cover - 70D	1
53	27762	AL	27762	AL	Crankcase w/Guide Pins (See Tech Bulletin 118)	1
54	27488	S	27488	S	Pin, Guide	2
56	27790	POP	27790	POP	Pan, Oil	1
59	125824	STCP R	92538	S	Screw, HHC Sems (M6x16)	2
64	27784	CM	27784	CM	Pin, Crosshead	3
65	48719	SSHS	48719	SSHS	Rod, Plunger	3
70	27785	NBR	27785	NBR	Seal, Crankcase Oil - 70D	3
75	110669	S	110669	S	Slinger, Barrier	3
88	110670	S	110670	S	Washer, Keyhole	3
90	48535	CC	48535	CC	Plunger, Ceramic (M25x110)	3
95	126549	STCP R	48679	SS	Stud, Plunger Retainer (M7x103)	3
96	20184	PTFE	20184	PTFE	Back-up-Ring, Plunger Retainer	3
97	14190	NBR	14190	NBR	O-Ring, Plunger Retainer - 70D	3
	14161	FPM	14161	FPM	O-Ring, Plunger Retainer - 70D	3
	◆ 48239	EPDM	◆ 48239	EPDM	O-Ring, Plunger Retainer - 70D	3
98	44069	SS	44069	SS	Gasket, Plunger Retainer	3
99	44068	SS	44068	SS	Retainer, Plunger (M7)	3
100	49788	NY	49788	NY	Retainer, LPS, Front [03/11]	3
	49789	NY	49789	NY	Retainer, LPS, Rear [03/11]	3
101	48487	—	48487	—	Wick, Long Tab	3
106	44086	NBR	44086	NBR	Seal, LPS w/SS-Spg	3
	45846	FPM	45846	FPM	Seal, LPS w/SS-Spg	3
	76086	ST2	76086	ST2	Seal, LPS w/S-Spg	3
	◆ 49196	EPDM	◆ 49196	EPDM	Seal, LPS w/SS-Spg	3
107	48537	BB	48668	SS	Washer, LPS	3
110	48536	BBCP	48667	SS	Manifold, Inlet	1
112	11379	NBR	11379	NBR	O-Ring, Inlet Manifold - 70D	3
	14183	FPM	14183	FPM	O-Ring, Inlet Manifold	3
	◆ 701491	EPDM	◆ 701491	EPDM	O-Ring, Inlet Manifold - 70D	3
117	126510	STCP R	88398	S	Screw, HSH (M12x35 and M12x40)	4
126	48538	BB	48669	D	Adapter, Female	3
	—	—	76667	SS	Adapter, Female	3
127	44610	STG	44610	STG	V-Packing	6
128	48539	BB	113025	SS	Adapter, Male	3
141	48672	SS	48672	SS	Spring, Coil [12/02]	18
142	48550	BB	48670	SS	Spacer w/Coil Springs	3
155	17629	NBR	17629	NBR	O-Ring, Spacer-Rear - 80D	3
	14183	FPM	14183	FPM	O-Ring, Spacer-Rear	3
	◆ 701491	EPDM	◆ 701491	EPDM	O-Ring, Spacer-Rear - 70D	3
156	28243	PTFE	28243	PTFE	Back-up-Ring, Spacer-Rear	3
158	28243	PTFE	28243	PTFE	Back-up-Ring, Spacer-Front	3
159	17629	NBR	17629	NBR	O-Ring, Spacer-Front - 80D	3
	14183	FPM	14183	FPM	O-Ring, Spacer-Front	3
	◆ 701491	EPDM	◆ 701491	EPDM	O-Ring, Spacer-Front - 70D	3
162	48363	D	48363	D	Back-up-Ring, Seat	6
163	26142	NBR	26142	NBR	O-Ring, Seat - 80D	6
	14330	FPM	14330	FPM	O-Ring, Seat - 70D	6
	◆ 701493	EPDM	◆ 701493	EPDM	O-Ring, Seat	6
164	48544	S	48676	SS	Seat	6
166	45839	SS	45839	SS	Valve	6
167	45840	SS	45840	SS	Spring	6
168	110682	PVDF	110682	PVDF	Retainer, Spring	6
170	44794	SS	44794	SS	Washer, Spring Retainer	6
171	48689	SS	48689	SS	Spring, Coil [12/02]	6
172	17667	NBR	17667	NBR	O-Ring, Valve Plug - 80D	6
	11745	FPM	11745	FPM	O-Ring, Valve Plug - 70D	6
	◆ 48240	EPDM	◆ 48240	EPDM	O-Ring, Valve Plug	6
174	120693	BBCP	49295	SS	Plug, Valve (w/O-Ring Model 2510 Only)	6

EXPLODED VIEW

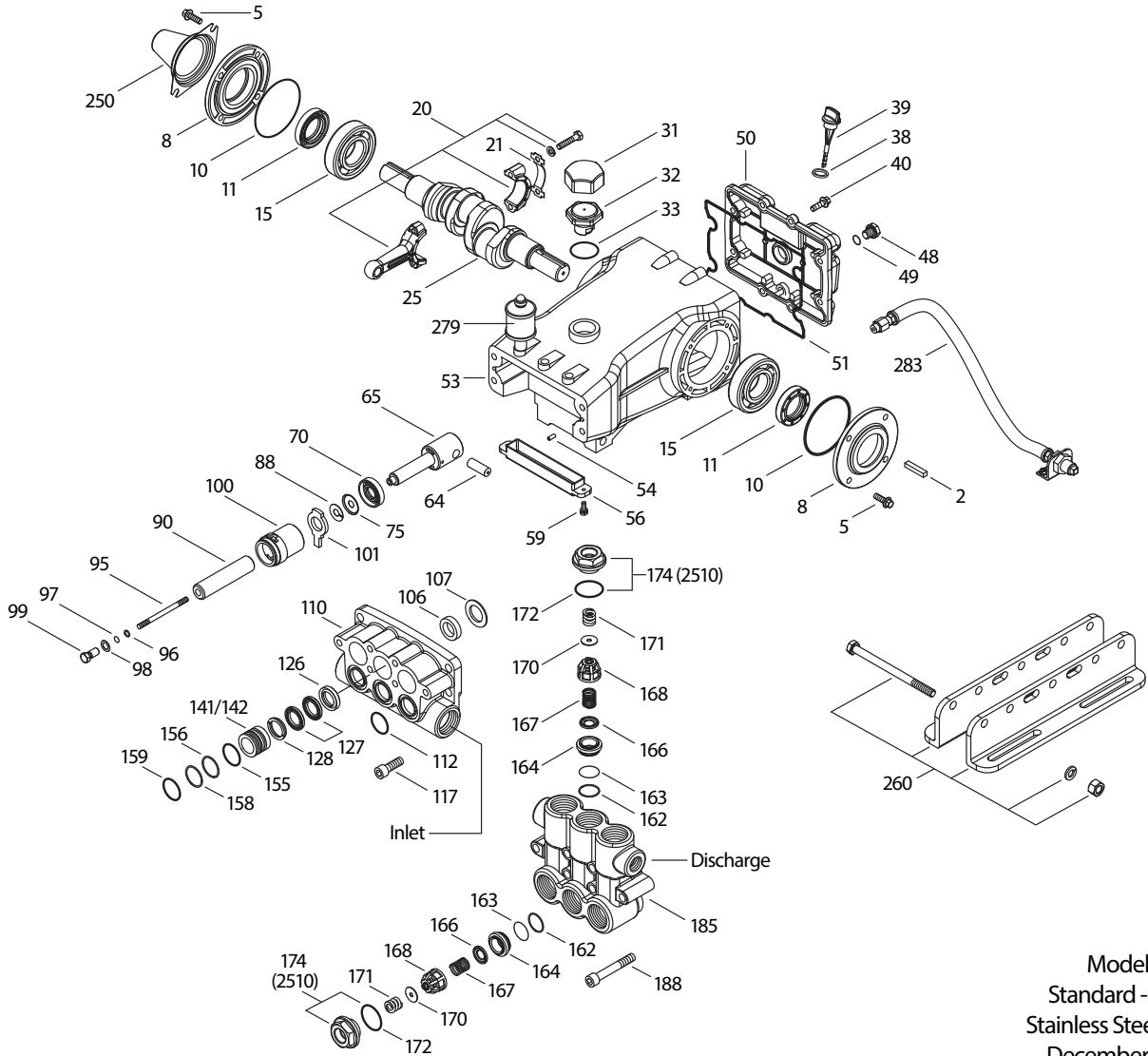

Models
Standard - 2510
Stainless Steel - 2511
December 2016

ITEM	PART NUMBER	MATL	PART NUMBER	MATL	DESCRIPTION	QTY
	2510		2511			
185	48543	BBCP	48674	SS	Manifold, Discharge	1
188	126511	STCP R	88399	S	Screw, HSH (M12x80)	6
250	26516	STCP	26516	STCP	Protector, Shaft	1
260	30614	STZPR	30614	STZPR	Mount, Rail, Assy	1
270	30059	STL	30059	STL	Hub, "H", M30 (Keyway M8) [Tech Bulletin 003] (Not Shown)	1
279	30278	STZP	30278	STZP	Oilers (1 oz.)	3
283	34334	—	34334	—	Kit, Oil Drain (3/8" x 24") (See Individual Data Sheet)	1
290	6124	—	6124	—	Gasket, Liquid (3 oz)	1
299	816747	BBCP	816785	SS	Head, Complete w/NBR Seals and O-Rings	1
300	31280	NBR*	—	—	Kit, Seal (Incls: 97, 106, 112, 127, 155, 156, 158, 159) Standard	1
—	—	—	76180	NBR*	Kit, Seal w/FA (Incls: 97, 106, 112, 126, 127, 155, 156, 158, 159) Standard	1
—	31380	FPM*	31380	FPM*	Kit, Seal (Incls: 97, 106, 112, 127, 155, 156, 158, 159) .0110	1
—	76376	STHT	76376	STHT	Kit, Seal (Incls: 97, 106, 112, 127, 155, 156, 158, 159) .3400	1
—	76291	STHT	76291	STHT	Kit, Seal (Incls: 97, 106, 112, 127, 155, 156, 158, 159) .3410	1
◆	76200	EPDM*	◆ 76200	EPDM*	Kit, Seal W/FA (Incls: 97, 106, 112, 126, 127, 155, 156, 158, 159) .0220	1
310	31285	NBR	31270	NBR	Kit, Valve (Incls: 162, 163, 164, 166, 167, 168, 170, 172) Standard, .3400	2
—	31385	FPM	31275	FPM	Kit, Valve (Incls: 162, 163, 164, 166, 167, 168, 170, 172) .0110, .3410	2
◆	76197	EPDM*	◆ 76370	EPDM*	Kit, Valve (Incls: 162, 163, 164, 166, 167, 168, 170, 172) .0220	2
—	6100	—	6100	—	Oil, Case (12 Bottles) ISO 68 Hydraulic (Fill to specified crankcase capacity prior to start-up)	1
—	—	—	6119	—	Lubricant, Anti-Seize (2 oz.) (See Tech Bulletin 095)	1

Bold part numbers are unique to a particular pump model. Italics are optional items. [] Date of latest production change.

R Components comply with RoHS Directive. * Review material codes for individual items (STG generally may be used as alternate).

See Tech Bulletins 003, 024, 035, 036, 043, 074, 083, 085, 095 and 118 for additional information.

MATERIAL CODES (Not Part of Part Number): ABS=ABS Plastic AL=Aluminum BB=Brass BBCP=Brass/Chrome Plated CC=Ceramic CM=Chrome-Moly D=Acetal F=Cast Iron FCM=Forged Chrome-Moly FPM=Fluorocarbon NBR=Medium Nitrile (Buna-N) NY=Nylon PE=Polyethylene POP=Polypropylene PTFE=Pure Polytetrafluoroethylene PVDF=Polyvinylidene Fluoride S=304SS SS=316SS SSHS=316SS/High Strength STCP=Steel/Chrome Plated STG=Special Blend PTFE White STHT=Special PTFE High Temp STL=Steel ST2=Special PTFE 2 STZP=Steel/Zinc Plated TNM=Special High Strength

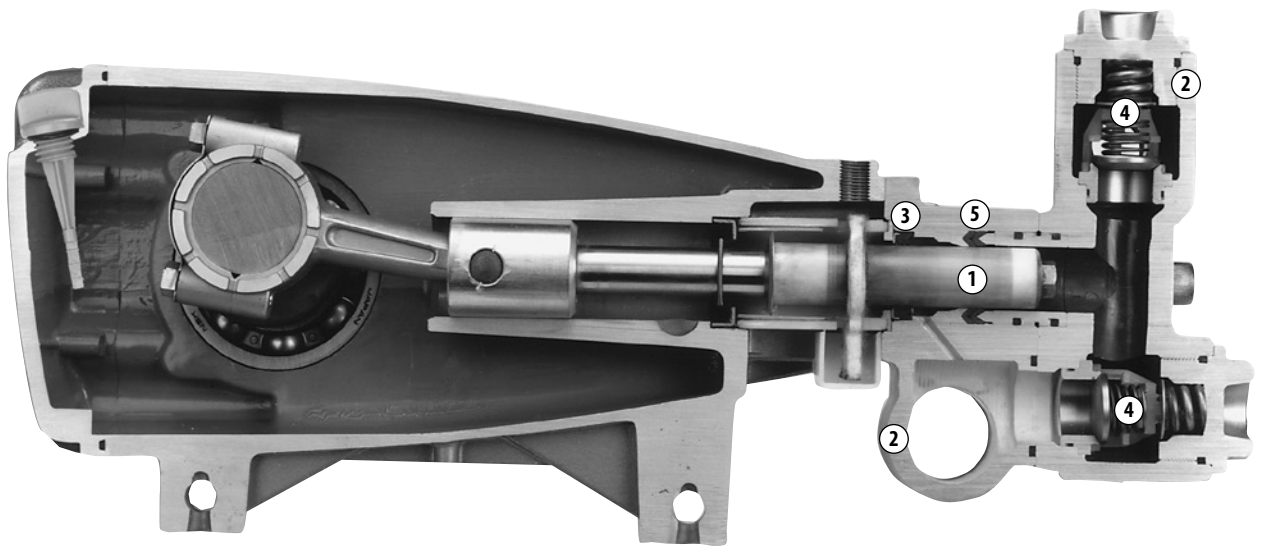
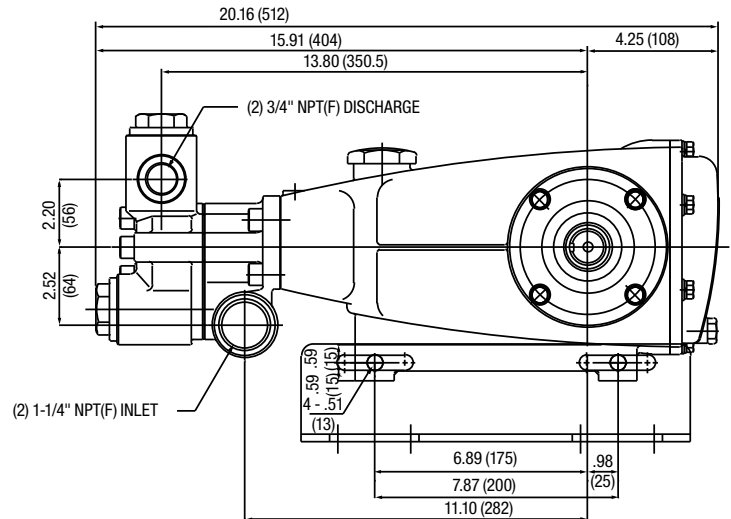
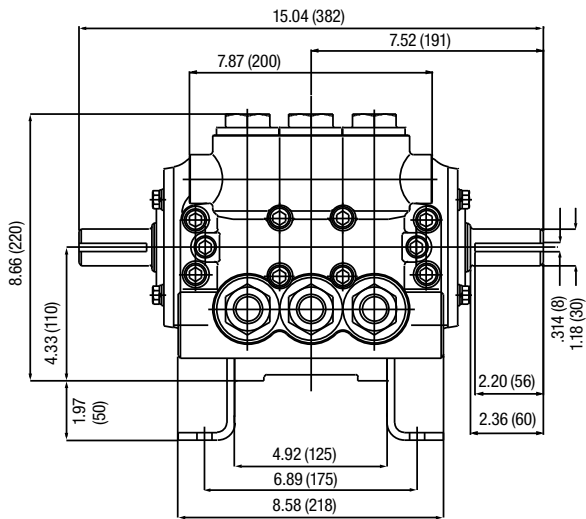

1. Special concentric, high-density, polished, solid ceramic **plungers** provide a true wear surface and extended seal life.
2. **Manifolds** are a high strength forged brass or stainless steel for long-term, continuous duty.
3. 100% wet **seal** design adds to service life by allowing pumped liquids to cool and lubricate on both sides of seals.
4. Stainless steel **valves, seats and springs** provide corrosion-resistance, ultimate seating and extended life.
5. Specially formulated, Cat Pumps exclusive, **V-Packings** offer unmatched performance and seal life.

⚠ CAUTIONS AND WARNINGS

All High Pressure Systems require a primary pressure regulating device (i.e. regulator, unloader) and a secondary pressure relief device (i.e. pop-off valve, relief valve). Failure to install such relief devices could result in personal injury or damage to pump or property. Cat Pumps does not assume any liability or responsibility for the operation of a customer's high pressure system.

Read all CAUTIONS and WARNINGS before commencing service or operation of any high pressure system. The CAUTIONS and WARNINGS are included in each service manual and with each Accessory Data sheet. CAUTIONS and WARNINGS can also be viewed online at www.catpumps.com/cautions-warnings or can be requested directly from Cat Pumps.

WARRANTY

View the Limited Warranty on-line at www.catpumps.com/warranty.



CAT PUMPS

1681 - 94TH LANE N.E. MINNEAPOLIS, MN 55449-4324
PHONE (763) 780-5440 — FAX (763) 780-2958
e-mail: techsupport@catpumps.com
www.catpumps.com